

[12] Patent

[11] Patent No.: GC 0000143	Number of the Decision to Grant the Patent: 4/2179
[45] Date of Publishing the Grant of the Patent: 29/06/2005 4/2005	Date of the Decision to Grant the Patent: 27/12/2004
[21] Application No.: GCC/P/2000/973 [22] Filing Date: 25/10/2000 [30] Priority: [31] Priority No. [32] Priority date [33] State 09/429804 29/10/1999 US 09/514866 28/02/2000 US [72] Inventors: 1- William B. Underhill, 2- Cengiz Esmersoy, 3- Brian Clark, 4- Jean- Michel Hache [73] Owner: Servicios de Perfilajes Electronicos S. A., Craigmuir Chambers, Road Town, Tortola, British Virgin Islands [74] Agent: Suleiman Ibrahim Al-Ammar	[51] Int. Cl. ⁷ : E21B 47/12 [56] Cited Documents: - GB 2334982 A (BAKER HUGHES) 08 September 1999 - US 5955966 A (SCHLUMBERGER) 21 September 1999 - US 5065825 A (INSTITUT FRANCAIS DU PETROLE) 19 November 1991

[54] METHOD AND APPARATUS FOR COMMUNICATION WITH A DOWNHOLE TOOL

[57] Abstract: Methods and apparatus for communication with a downhole tool including uphole (or remote) and downhole equipment. The uphole or remote equipment includes a signal source (or array) coupled to a programmable triggering system and a precision clock. Optionally, the uphole equipment may include receivers for capturing reference signals near the source and may include telemetry equipment for receiving MWD signals from the downhole equipment. The downhole equipment includes one or more receivers, signal processing equipment, memory, and a precision clock. Optionally, the downhole equipment also includes MWD telemetry equipment for transmitting data to the surface. The methods include, but are not limited to, synchronizing the recordation of signals detected downhole with the firing of the signal source and processing the recorded signals to eliminate useless information. The methods present several techniques for true source signal recognition whereby actual signal information is extracted from the recordings of the receivers so that the ultimate stored data is compact and virtually 100% useful. This elimination of useless data conserves valuable telemetry time and/or enables longer operation of the apparatus before tripping out to retrieve stored data by using memory efficiently.

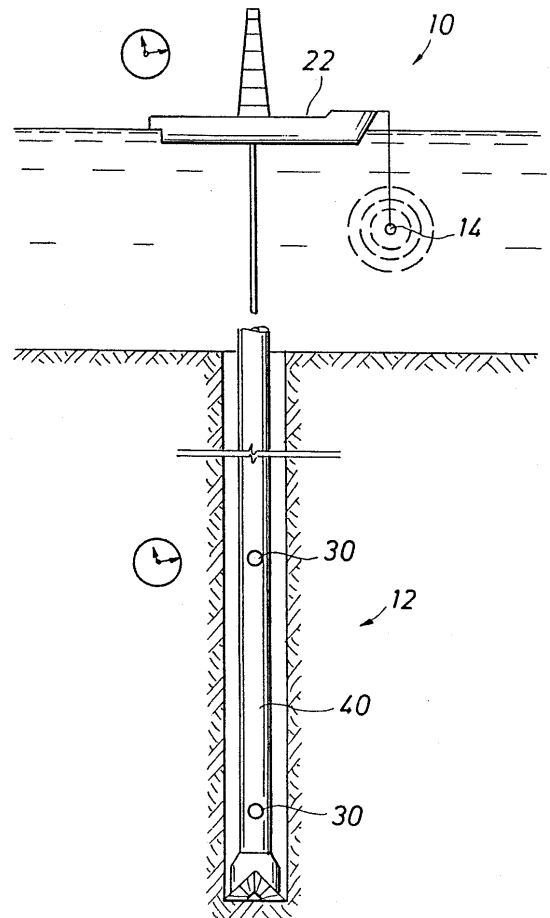

No. of claims: 16

No. of figures: 10